

M Function

Designed for shift-based applications, LockUp M function locks operate in shared use functionality to secure day use lockers or in assigned use functionality to secure private lockers.



- Solid metal housing with integrated pull handle
- Keypad operation
- Visual & audible indicators
- Customizable Settings
- Manage with Electronic Keys
- Optional User Key for ADA compliance
- Powered by 2 premium 9-volt batteries
- 3-5 year battery life
- 2 year warranty



- Surface mount
- Non-handed
- 3/8" solenoid bolt locking mechanism
- Tamper guard



Features

Front Unit

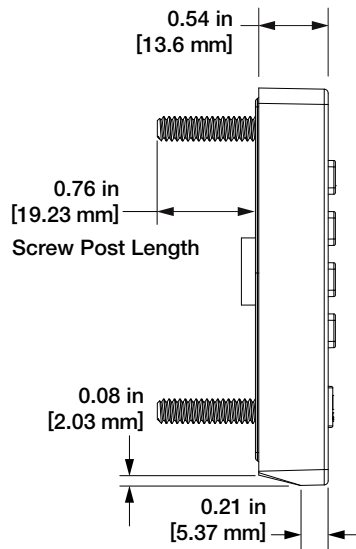
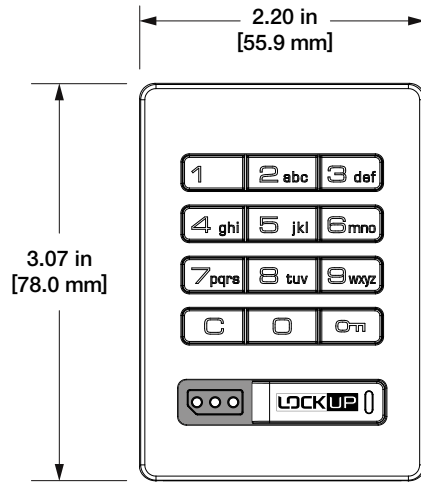

Rear Unit

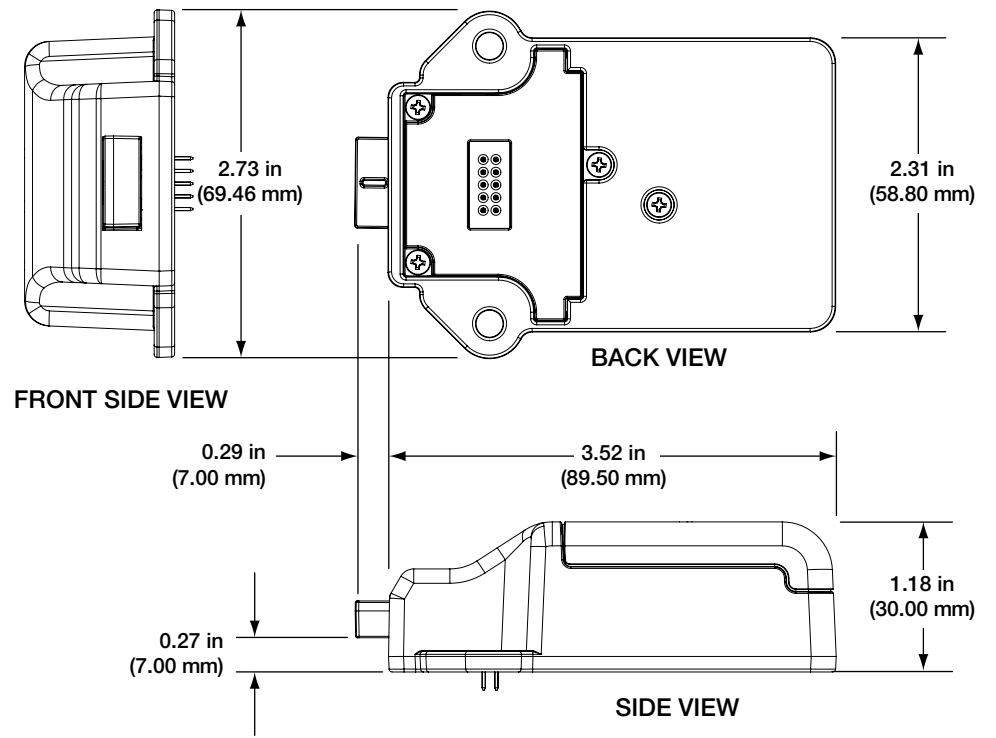

Standard Keypad locks with a pull handle and operated with a User Key are fully compliant with the Americans with Disabilities Act (ADA) guidelines set by the U.S. Access Board.

